

Sal-Tech Easy Packaging Packaging Solutions

Cases & Boxes Erection & Closing

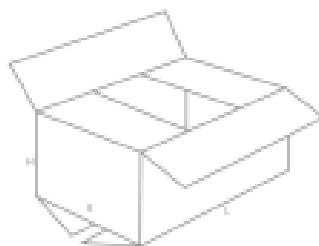

WE KEEP THINGS TOGETHER



STEP A-50W Series Bottom Side Belt Drive Carton sealer

is a carton bottom sealer equipped with a side conveyor belt for moving of boxes for sealing purposes. This machine has a safety emergency button for protecting operators when need arises. As for its adhesive tape dispenser, width compatibility is either of the following: 48mm, 60mm, or 70mm. This is lightweight yet offers quality results and performance for simple to heavy duty carton sealing requirements.

Features:

- Quality Components
- Side Belt Conveyor
- Adjustable Carton Size
- Universal Type Sealer
- Safety System
- Painted Steel

Options:

- Stainless-Steel Types

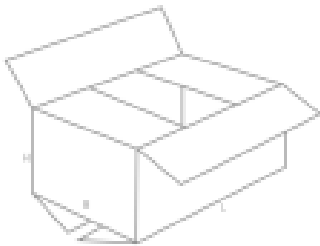

SPECIFICATIONS:	
Dimension (LWH)	1020mm x 850mm x 650mm
Weight	80kg
Model	STEP A-50W
Conveyor Speed	20 meters per minute
Packing Size Maximum (LWH)	L ∞mm x W 500mm x H 800mm
Packing Size Minimum (LWH)	150mm x 150mm x 50mm
Power Supply	230V, 60HZ, 1Ph with Siemens Plug or Request for Other Voltage Version
Power	240W
Adhesive Tape Width	48-50mm/60mm/75mm
STEP Item No.	42111010

STEP A-50 Series Top & Bottom Side Belt drive Tape Carton Sealer

is a primary carton sealer that has side belts. It is made intricately with imported parts, that is also guaranteed high in quality for sealing processes. An equipment designed to work on securing heavy-loaded cartons, STEP A-50 also has options on steel and stainless-steel type for instance where machine will be put on humid environments.

Features:

- Quality Components
- Side Belt Driven
- Adjustable Carton Size for carton type Fefco 0201.
- Safety System
- Painted Steel
- Compatible for heavy carton sealing requirements

Options:

- Stainless steel

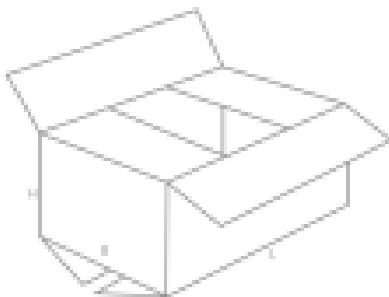

SPECIFICATIONS:	
Dimension (LWH)	1020mm x 900mm x 1350mm
Weight	130kg
Model	STEP A-50
Conveyor Speed	20 meters per minute
Packing Size Maximum (LWH)	L ∞mm X W500mm x H500mm
Packing Size Minimum (LWH)	L 150mm x W 150mm x H 150mm
Power Supply	230V 50/60Hz 1P with Siemens Plug or Request for Other Voltage Version
Adhesive Tape Width	48-50mm / 60mm / 75mm
Motor Effect Usage	360W
STEP Item No.	42111020
Stock Status	Typically on Stock

STEP A-50P Series Top & Bottom Side & Top Belts Driven Tape Carton Sealer

is a primary carton sealer that has an installed top and side belt. It is made intricately with imported parts, that is also guaranteed high in quality for sealing processes. An equipment designed to work on securing heavy-loaded cartons, STEP A-50P also has options on steel and stainless-steel type for instance where machine will be put on humid environments.

Features:

- Quality Components
- Side Belt Driven
- Top Belt Driven
- Adjustable Carton Size
- Safety System
- Painted Steel
- Compatible for heavy carton sealing requirements

Options:

- Stainless Steel



SPECIFICATIONS:	
Dimension (LWH)	1020mm x 900mm x 1350mm
Weight	140kg
Model	STEP A-50P
Conveyor Speed	20 meters per minute
Packing Size Maximum (LWH)	L ∞mm X W500mm x H500mm
Packing Size Minimum (LWH)	L 150mm x W 150mm x H 150mm
Power Supply	230V 50/60Hz 1P with Siemens Plug or Request for Other Voltage Version
Adhesive Tape Width	48-50mm / 60mm / 75mm
Power	360W
STEP Item No.	42111030

STEP B-56 Series Top & Bottom, Top & Bottom Belt Drive Tape Carton Sealer

STEP B-56 Top and Bottom Driven Carton Sealer a carton sealer that can completely utilized bulk packaging lines. Has a dual sealing characteristic on top and bottom, suitable for heavy packages. Built with an advanced pneumatic control system that most modern industrial equipment has. Serves as an advantage since its low cost in maintenance and easy to operate.

Features:

- Advanced model parts, electrical and pneumatic
- No downtime when feeding of cartons for sealing
- Custom built to change carton size manually
- Top and bottom driven belt conveyor
- Guaranteed Quality
- Emergency button for safety
- Rollers to keep box intact



SPECIFICATIONS:	
Dimension (LWH)	L 1020x W 850 x H 1450mm
Weight	130KG
Model	STEP S-50
Conveyor Speed	20m/min.
Packing Size Maximum (LWH)	L150 ∞ x W 180 – 500 x H150 – 600mm
Power Supply	230V 50/60Hz 1P with Siemens Plug or Request for Other Voltage Version
Adhesive Tape Width	48-50/60/75mm
Power	240 W
STEP Item No.	42111050
Stock Status	Typically on Stock

STEP E-50 Random top/bottom Side Belt Drive Tape Carton Sealer

STEP E-50 Automatic Side Belts Driven Carton Sealer a carton sealer with side belt conveyor to guide cartons being sealed and automatically adjusts relying on changeable dimensions. One of industrial carton sealer equipment that is easy to use in its manageable design. Everyone in the packaging lines can easily install an adhesive tape with width ranging 48/60/75mm, though can be use different sizes but important to use only one tape size according to the boxes being sealed to avoid consuming time.

Features:

- Automatically adjusts the height and width based on carton sizes;
- Advanced pneumatic control system compared with the complicated electrical control system;
- Side belts on both sides with top and bottom sealing;
- Universal type, fit for all kinds of cartons
- Safety Emergency button



SPECIFICATIONS:	
Dimension (LWH)	L1170xW900xH1350mm
Weight	170KG
Model	STEP E-50
Conveyor Speed	20m/min
Packing Size Maximum (LWH)	L150-∞xW150-500xH140-500mm
Power Supply	230V 50/60Hz 1P with Siemens Plug or Request for Other Voltage Version
Adhesive Tape Width	48-50/60/75mm
Power	240W
STEP Item No.	42111090

Options:

- The parts of case sealer is Imported, include electrical and pneumatic components
- Automatically adjust the height and the width for different size of cartons;
- Side belts driven; top and bottom sealing of carton sealer
- Cutter Safety system to prevent hands from the cutter

STEP E-50P Random top/bottom Carton Tape Closer

STEP E-50P Automatic Top and Side Belt Driven Carton Sealer adding a more convenient and smooth operation in a complex packaging line that is suitable to any carton sizes. Aside of having belts for bottom guide the top was also presented its own driving belt conveyor installed upside down, functions also as a guide to secure cartons while being sealed from the top.

Features:

- Taking you to the next level with its:
- Automatically adjusts the height and width based on carton sizes;
- Advanced pneumatic control system compared with the complicated electrical control system;
- Side and top belts driven with top and bottom sealing;
- Universal type, fit for all kinds of cartons
- Safety Emergency button
- Safety cutter system to prevent hands on touching the cutter



SPECIFICATIONS:	
Dimension (LWH)	L1170xW900xH1350mm
Weight	180KG
Model	STEP E-50P
Conveyor Speed	20m/min
Packing Size Maximum (LWH)	L150-∞xW150-500xH150-500mm
Power Supply	230V 50/60Hz 1P with Siemens Plug or Request for Other Voltage Version
Adhesive Tape Width	48-50/60/75mm
Power	360W
STEP Item No.	42111100

Options:

- The parts of case sealer is Imported, include electrical and pneumatic components
- Automatically adjust the height and the width for different size of cartons;
- Side belts driven; top and bottom sealing of carton sealer
- Cutter Safety system to prevent hands form stabbed by the cutter

STEP C-50 Series Top & Bottom Side Belt Drive Auto Flap Folding Tape Carton Sealer

A flap folding and sealing machine, the **STEP C-50 Semi Auto Flaps Folding Carton Sealer** is made for heavy duty operation for large scale businesses with long list of box sealing requirements. It has an installed photoelectricity induction system that helps in the process of securing the flaps of corrugated boxes, then after, it tightly keeps safe products with a top and bottom adhesive. Added safety with a safety system that avoids damages from fixed cutter.

Features:

- Quality Components
- Safety System
- Semi-Automatic machine
- Photoelectricity Induction System
- Steel and Stainless-Steel Types
- Heavy Duty Design
- Hotmelt Glue Sealing



Hotmelt glue sealing



SPECIFICATIONS:	
Dimension (LWH)	1770mm x 850mm x 1520mm
Weight	250kg
Model	STEP C-50
Speed	20 meters per minute
Packing Size Maximum (LWH)	600mm x 500mm x 500mm
Packing Size Minimum (LWH)	200mm x 150mm x 150mm
Power Supply	230V 50/60Hz 1P with Siemens Plug or Request for Other Voltage Version
Adhesive Tape Width	48-50mm / 60mm / 75mm
Power	400W
STEP Item No.	42111120

STEP I-50 Random Top & Bottom, Side Belt Drive Tape carton Sealer

STEP I-50 Automatic Flaps Folding Carton Sealer an automated machine that folds the top flaps, then seals top and bottom by adhesive tape. The sensor installed on top of the machine identifies an incoming carton, and an adjustable air pressure gives force on folding the top flaps. A very easy to operate and maintain provided by the electronic box control system.

Features:

- Automatically adjusts the height and width based on carton sizes;
- Advanced pneumatic control system compared with the complicated electrical control system;
- Fold the top covers automatically, side belts driven top and bottom sealing;
- Safety cutter system to prevent hands on touching the cutter
- Sensor detecting the incoming carton
- Air pressure can be adjusted
- Electronic box control system



SPECIFICATIONS:	
Dimension (LWH)	L170xW880xH1450mm
Weight	280KG
Model	STEP I-50
Conveyor Speed	20m/min
Packing Size Maximum (LWH)	L200-500xW150-500xH150-500mm
Power Supply	230V 50/60Hz 1P with Siemens Plug or Request for Other Voltage Version
Adhesive Tape Width	48-50/60/75mm
Power	240 W
STEP Item No.	42111130

Options:

- The parts of case sealer is Imported, include electrical and pneumatic components
- Automatically adjust the height and the width for different size of cartons;
- Folds top cover by air pressure; side belts driven top and bottom sealing of carton sealer.
- Cutter Safety system to prevent hands form stabbed by the cutter.
- Safety fence.

STEP G-50

The **STEP G-50 Semi-Automatic Side and Corner Sealing** Machine sealing machine focuses on the corner edges of a carton using an adhesive tape. Designed to be lightweight with correlated pulleys and flexible for an easy relocation, installation and to combine with the compatible sealing machines. Set up with driven motor interfacing with the conveying belt, once the carton starts its process and has an air cylinder to hold the two adhesive tapes on top of both sides.

Features:

- Suitable for sealing cartons with equal dimensions
- Induction control system utilizes photoelectricity
- Automatically turn cartons 90° and push for sealing
- With a safety cutter to avoid accident
- Has steel and stainless-steel types
- High quality imported components.



SPECIFICATIONS:	
Dimension (LWH)	L1900xW1130xH1530mm
Weight	580KG
Model	STEP G-50
Conveyor Speed	20m/min
Packing Size Maximum (LWH)	L320-500xW200-500xH180-500mm
Table Height	Min H500mm Max H750mm
Power Supply	230V 50/60Hz 1P with Siemens Plug or Request for Other Voltage Version
Adhesive Tape Width	W48-50/60/75mm*L1000 code
Sealing speed	460 -600 pcs/hr
STEP Item No.	42111140

Option:

- Combine to STEP A-50P Top, Bottom and Side Belts Carton Sealer, STEP B-56 Top and Bottom Driven Carton Sealer, and STEP C-50 Top & Bottom Sealing Machines and Flap Folding to complete end-of-line process.

STEP K-40 Automatic Carton Erector and Bottom Sealing

Machine is a carton erector added with a bottom sealing function. This machine is suitable for forming, folding, and sealing of boxes, eliminating downtime with its easy carton infeed feature. Engineered to simultaneously prepare boxes for other purposes, this equipment is also enhanced to keep employees or operators safe from cutter injuries. Improving a safe and fast forming to sealing process. An adhesive tape width of 48mm, 60mm, or 75mm is compatible with the machine, certainly pushing productivity at the top.

Features:

- High Standard Materials: Electrical and pneumatic parts are imported and of high standard quality
- Easy Feeding of Cartons: Cartons may be added without stopping machine operation, eliminating downtime
- Forming and Sealing: Applicable for forming and sealing cartons of same sizes
- Adjustable Carton Size: Manual modification to change carton size, finishing in 2 to 3 minutes
- Photoelectricity Induction Control System
- Safety System: Cutter is safe for use, and injuries from stabs are prevented
- Durable and Compact Built: Reduces waste of time as machine forms, folds, and seals simultaneously
- Vertical Storage
- Lightweight
- Speed
- Quality Performance



SPECIFICATIONS:	
Dimension (LWH)	2000mm x 1900mm x 1450mm
Weight	450kg
Model	STEP K-40
Speed	12 cartons per minute
Carton Size Capacity (LWH)	250mm-450mm x 150mm-400mm x 100mm-400mm
Power Supply	230V, 50Hz, 200W with Siemens Plug or Request for Other Voltage Version
Air Compression	6kg/cm ³
Air Consumption	450NL/minute
Adhesive Tape Width	48-50mm/60mm/75mm
STEP Item No.	42121010

STEP K-40H18 Carton Forming and Bottom Sealing

Machine is a former and sealer of corrugated boxes. Difference from STEP K-40 is the added output per minute - measured as 18 boxes/min. This is innovatively designed to cater medium to large scale businesses that has high demand on box processing. Lightweight compared to other machines of same output in the market and is proven excellent when it comes to performance.

Features:

- High Standard Materials: Electrical and pneumatic parts are imported and of high standard quality
- Easy Feeding of Cartons: Cartons may be added without stopping machine operation, eliminating downtime
- Forming and Sealing: Applicable for forming and sealing cartons of same sizes
- Adjustable Carton Size: Manual modification to change carton size, finishing in 2 to 3 minutes
- Photoelectricity Induction Control System
- Safety System: Cutter is safe for use, and injuries from stabs are prevented
- Durable and Compact Built: Reduces waste of time as machine forms, folds, and seals simultaneously
- Vertical Storage
- Lightweight
- Speed
- Quality Performance



SPECIFICATIONS:	
Dimension (LWH)	2400mm x 2050mm x 200mm
Adhesive Tape	48/60/75mm
Weight	550kg
Model	STEP K-40H18
Packaging Size (LWH)	200-400mm x 150-350mm x 100-350mm
Speed	18 cartons per minute
Power Supply	220V 50Hz 200W with Siemens Plug or Request for Other Voltage Version
Air Compression	6kg/cm ³
Air Consumption	450NL/minute
STEP Item No.	42121020

STEP E3CC 116 CARTON ERECTOR

Semi-Automatic Carton Erector Specifications:

- Dimension of Cartons:
- Length: 200 to 640mm
- Width: 140 to 500mm
- Height: 75mm to no limits
- Machine dimension L1955xB890xH1700(+220, Height adjustment)
- Machine weight 90kgs
- Electrical Supply 1x230V 50Hz
- Pneumactical Supply 6bar 250NL
- Country of Origin Taiwan
- Status of stock: Carried On Order

Item No.: 42100116

Carton/Box/Case Erectors for Packaging

STEP CF-10T Carton Forming Machine

The STEP CF-10T forms the carton box by folding bottom of the box. The machine uses AIRTAC Cylinder, AIRTAC Valve, AIRTAC Pneumatic Control Valve and Festo Air time delay relay. It can also be used as the packing platform.

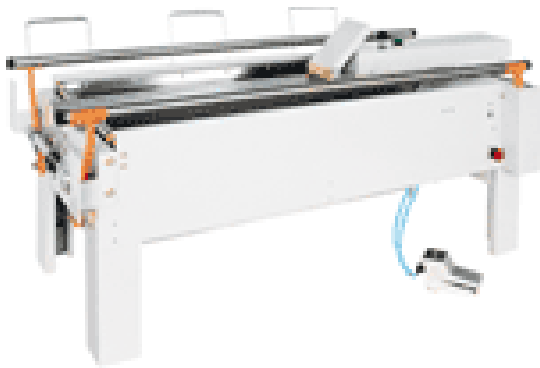

Specifications	
Air Pressure	4 kg / square cm
Carton Size (LxWxH)	200-600 x 150-480 x 120-480mm
Table Feet Cup Height	600-780mm (adjustable)
Table Caster Height	700-880mm (adjustable)
Dimensions (LxWxH)	1500x900x(780 outriggers / 880 casters)
Machine Weight	80kg
Item Number	

POSELUKNING med tape

ND 8300 15 - 25 MM TAPE SÆKKELUKKER MED KNIV 42218010	Pose/sækkelukker for bord montering For tape bredde angivet.	
T-910 - 10 MM TAPE SMÅ POSER 42218020	Rullelængde af tape 66/100 m Kernediameter ø76 mm	
T-916 - 10 MM TAPE MED KNIVSMÅ POSER 42218030	T-916 vist på billede	



STEP Automatic Tape Dispensers

STEP M1000 Automatic Tape Dispenser

The STEP M1000 is a freely switching dispenser and good for cutting adhesive tapes. It has a length setting to evade from repeating process of the tape. Operating process made by fire resistant and anti-static materials that can fight back 480 degrees temperature.

STEP M1000S Automatic Tape Dispenser

M-1000S tape dispenser is a length adjustable with two shift models. The automatic and manual. It cleanly cuts sensitive tapes like masking tapes, scotch tapes etc. It has a strong casing switch.



Specifications	STEP M1000	STEP M1000S	STEP RT 5000
Power Supply	AC220V/50Hz AC110V/60Hz	AC220V/50Hz AC110V/60Hz	AC220V/50Hz AC110V/60Hz
Cutting Tape Type	Apply for adhesive tape	Apply for adhesive tape	Any tape
Cutting Width	7-50mm	7-50mm	5-55mm
Cutting Length	20-999mm±1	5-999mm±1	5-999mm±1
Outline Dimension	(LxWxH) 150x137x245 mm	(LxWxH) 150x137x245 mm	(LxWxH) 115x215x230 mm
Machine Weight	2.4kg	2.4kg	3.0kg
Item Number	42216000	42216010	42216040

STEP RT-5000 Tape Dispenser

STEP RT-5000 Tape Dispenser is generally tape cutter. It is specialized for three sets of tape length that cut together and continuously. Good for Adhesive and non- adhesive tapes.



STEP Manual Tape meters SL-1 and SL-3

SL 1

25 MM TAPE

Tape roll length 66 m
25 mm width tape

Item Number
42215010



SL-3

25-75 MM TAPE

Tape roll length 330 m
25, 38, 50 or 75 mm width tape.

Item Number
42215020

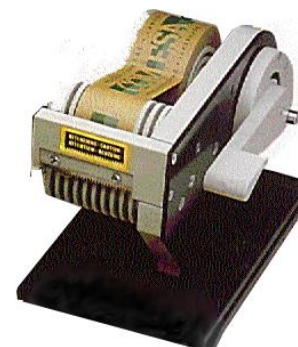

STEP ZCUT-2 Tape Dispenser

The STEP ZCUT-2 Tape Dispenser has an adjustable length that can cut narrow and soft tapes. Very easy to operate.

Specifications ZCUT 2	
Output power	AC220V/50Hz AC110V/60Hz
Cutting Tape Type	Narrow and Soft Tape
Cutting Width	3-25mm
Cutting Length	13-59mm
Applicable Tape Max Outer Diameter	130mm
Machine Weight	4.0kg
Item Number	42216010



STEP ZCUT-9 Tape Dispenser

The STEP ZCUT-9 Tape Dispenser can use any size of tapes and can use two rolls together. The memory function can set up to six different lengths before use



Specifications ZCUT 9	
Output power	AC220V/50Hz AC110V/60Hz
Cutting Tape Type	Apply for adhesive tape and Non-adhesive
Cutting Width	5-60mm
Cutting Length	5-999mm
Outline Dimension	(LxWxH) 213x116x140 mm
Machine Weight	4.0kg
Item Number	42216030

STEP ZCUT-870 Tape Dispenser

The STEP ZCUT-870 Tape Dispenser is adjustable to fit different size of the width and length rolls with mobile transducer for cutting tapes. Shifting of blade is easy and it has an edge protector for safety.

Specifications ZCUT 870	
Output power	AC220V/50Hz AC110V/60Hz
Cutting Tape Type	Apply for Adhesive Tape
Cutting Width	3-25mm
Cutting Length	8-70mm
Outline Dimension	(LxWxH) 256x126x150mm
Machine Weight	2.5 kg
Item Number	42216100



STEP A2000 Tape Dispenser

The **STEP A2000 Tape Dispenser** has a length setting that set a length and automatically cut. Also has a LED display for the size indication. Easy to remove and put in adhesive tapes.



Specifications A2000	
Output Power	AC220V/50Hz AC110V/60Hz
Cutting Tape Type	Apply for adhesive and non-adhesive tape
Cutting Width	7-50mm
Cutting Length	5-999mm±1
Outline Dimension	(LxWxH) 218x137x150mm
Minimum Length	5mm
Machine Weight	3.5KG
Item Number	42216050

STEP ED-100 Tape Dispenser

ED-100 Tape Dispenser has a LED display for size indication. Tape are automatically pulled and cut. Cutter can be easily removed and replaced.

Specifications EB100	
Output Power	220V/50HZ 110/60HZ
Power	18W
Cutting Length	5mm-999mm
Cutting Width	7mm-55mm
Machine Weight	2.45kg
Item Number	42216060



STEP AT80 Tape Dispensers

The STEP AT80 Tape Dispenser models have the same appearance and specification. With Maximum of 80mm width. Have also two shift models. The automatic and manual. It has also a length setting that adjusts length easily.

AT80-A Tape Dispenser is suitable for cutting all types of adhesive tape.

AT80-B Tape Dispenser is suitable in cutting protective films and wide sizes tapes.

Specifications	
Power Requirement	100V,120V,220-240V (150W-600W)
Dimensions	(LxWxH) 250x190x300mm
Weight	11kg
Tape Speed	132MM sec 50HZ 160MM sec 60HZ
Cutting Length	From 40MM to 999MM
Tape Width	From 15MM to 80MM
Item Number	42216200 A type 42216210 B type



STEP Bonus Tape Dispenser

The best way to apply Bonus Tapes is to use a specialized tape dispenser. The STEP Bonus Tape dispenser is custom built to accommodate Jumbo Bonus Tape rolls and operate in a comfortable and user-friendly manner. It is designed to be comfortable with a moulded handle to ensure a firm grip. High quality dispenser will apply your Bonus Tapes faster and more easily.

The STEP Bonus Tape Dispenser also allows Bonus Tapes to be applied smoothly and efficiently and has been specifically designed to REDUCE noise, optimizing your work environment.

We also offer big discounts on our Bonus Tape rolls that goes with the dispenser.

- The BIG tape dispenser built to efficiently dispense Bonus Tape Rolls
- Incorporates special noise-reducing technology for a quieter warehouse
- Moulded handle for a firmer grip and better application



STEP Tape Dispensers

High quality Bonus Tape dispenser equipped with anti reversing brake. Compatible with a variety of tape width and can carry 66 to 100 meters of tape with a core diameter of 76mm.

- Plastic roller
- Plastic wipe down
- Adjustable tension brake with control knob
- Heavy duty reinforced steel frame
- Grip made from high impact plastic
- Baked enamel finish

Specifications:

Model	Item No.	Tape Size	Price/unit
STEP T-251	42212010	50mm	
STEP T-256 Deluxe with Soft Handles	42212110	50mm	
Bonus Tape dispenser	42212020	50mm	
STEP T-510	42212030	75mm	
STEP T-553	42212040	100mm	



STEP T-400 Tape Dispenser

Closing tape dispenser available in variety of sizes. Suitable for strapping and bundling boxes to keep them secure.

Specifications:

Model	Item No.	Tape Size	
STEP T-400-1"	42212025	25mm	NA
STEP T-400-1½"	42212050	38mm	
STEP T-400-2"	42212060	50mm	



STEP PrintWiz® Hand-held Print on Demand Tape Gun

The STEP PrintWiz is a hand-held tape dispenser capable of directly printing custom texts and images on tape. It is ideal for branding and sealing carton boxes.

Features

- The smallest and most versatile, hand-held, mobile tape dispenser / printer / sealer.
- Transforms ordinary adhesive tape into printed tape with unique security features.
- Use standard packaging / sealing tape.
- Applicators to fit standard tape widths 48mm and 72 mm.
- Print only when required, with the aid of “on / off” printing lever.
- Easy to change printwheel.
- Special printwheel with additional security features for interchangeable plug-in letters.
- Easy and convenient ink cartridge replacement.
- Tape perforating device for enhanced security (Optional feature)

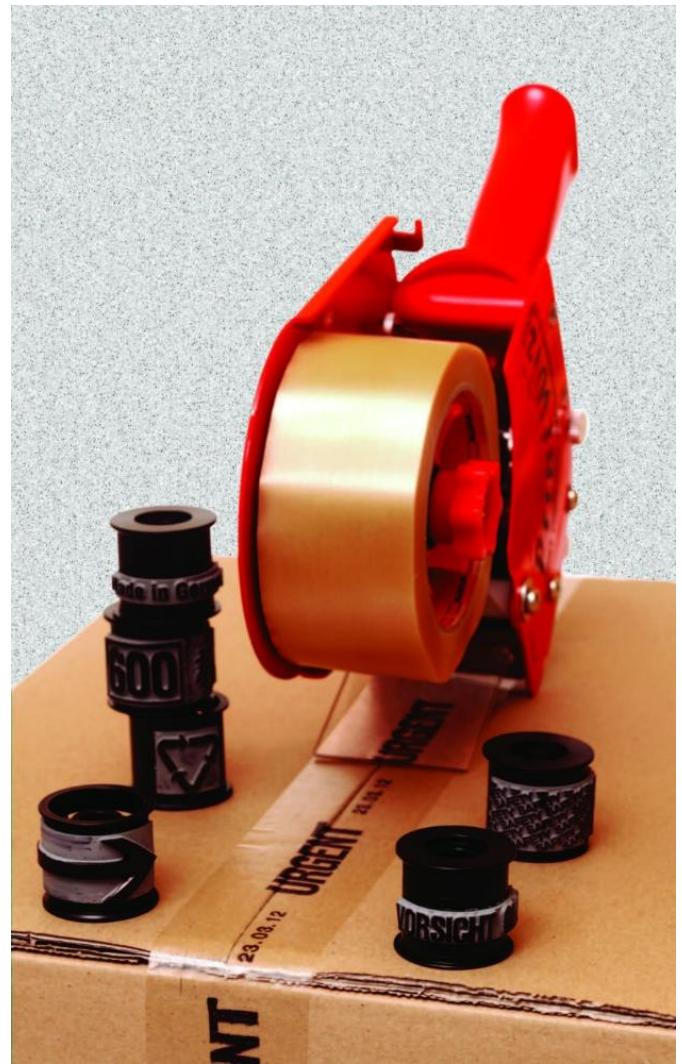

Item Numbers	Product for STEP PrintWiz (2") model	Prices per unit
42212200	STEP PrintWiz Hand-held Print on Demand Tape Gun (2") model	
42212510	Replacement Black Toner Cartridge	
42212520	Print Drum	
42212530	Alpha Numeric Font Set	
422126NN	Printing Plate(As long as it meets all artwork requirements)	
Item Numbers	Product for STEP PrintWiz (3") model	
42212300	STEP PrintWiz Hand-held Print on Demand Tape Gun (3") model	
42212620	Print Drum	

STEP Gummed Paper Dispensers

STEP FX-800 Manual Gummed Tape Dispenser

The STEP FX-800 is used for sticking the reinforced gummed tape which can lower packaging cost. Very easy to operate.

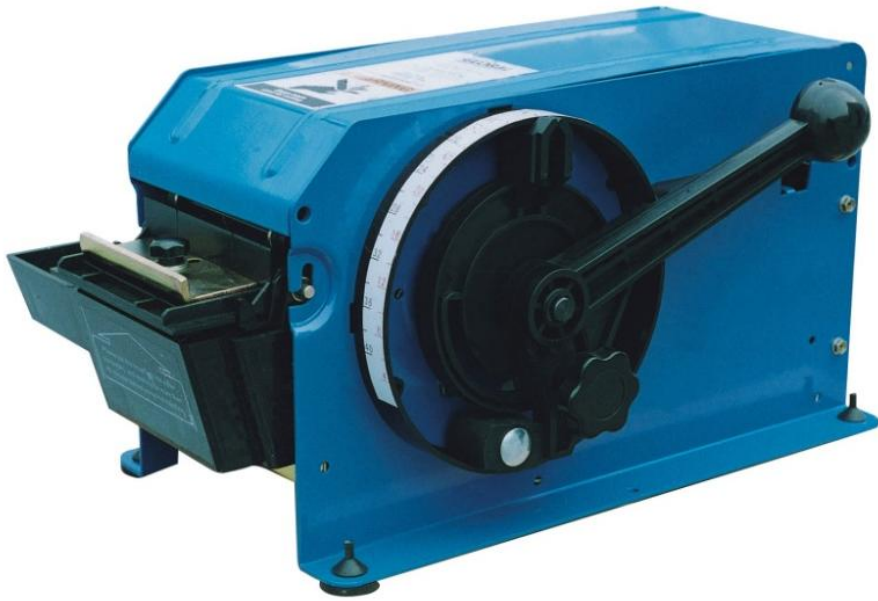

Specifications	
Width of Tape	20-80mm
Max. Tape Roll diameter	200mm
External Dimensions	480×330×320
Net Weight	35kg
Item Number	42216500



STEP FX-800P

Automatic Kraft Paper Dispenser

Gummed paper kraft tape are requiring special dispenser that lubricates the adhesive on the backing before the tape can be applied. STEP FX-800P is an Automatic Kraft Paper Dispenser Electronic craft tape machine. Made to create a swift work flow during sealing packages with kraft paper.



Features

- Adopting step motors for paper feeding and cutting
- High speed of feeding tape (1.1m/s)
- Intelligent operation
- Automatic paper releasing function
- Optional laser range finder
- Using a self-lubricating blade
- One-way valve on the water tank



Specifications	
Width of Tape	20-76mm
Max. Tape Roll diameter	230mm
Dispense length	150-9999mm
Speed	1,1 m/s
Voltage	84-240V 50-60Hz
Power	120W
External Dimensions	500×300×315mm
Weight	18kg
Item Number	42216510

REASONS WHY YOU NEED STEP FX-800P

- Save time and reduce waste
- Save Kraft Tape
- Reduce labor
- Increased output
- Increase product protection
- Reduce labor cost

STEP Gummed Paper Tapes

Compatible for use with a wide variety of tape dispensers, from manual to fully automated. It offers great adhesive capability for box and package sealing. It comes in two colors, brown and white. Gummed paper tapes are composed of a layer of paper obtained by combining 50% cellulose and 50% non cellulose components. The adhesive component can be made from either vegetable or animal glue.

Specifications:

	White	Brown
Weight	90 grams	70 grams
Package	70mmx200m per roll	70mmx200m per roll
Quantity	8 rolls per carton	6 rolls per carton
Item Number	55807060	55807065



Technical Features:

Vegetable Glue: based on carbohydrates, mainly starch and its derivatives namely; potatoes, corn etc.

Vegetable Glue characteristics:

- No smell
- Uniform water coating
- Longer open duration
- Slower bonding speed

Note: Vegetable glue absorbs more water than normal. Reduce water level in dispensers and switch top heaters on.

Animal Glue characteristics:

- Protein based adhesive.
- Made from animal bones, skin and sinews.
- Unpleasant smell.
- Irregular water coating
- Shorter open time
- Faster bonding

Note: Animal glue is water repellent. Adjust water level of dispenser higher than normal and switch the top heater on.

Advantages of STEP Gummed Paper Tapes

Utilizes Vegetable Glue

STEP Gummed Paper Tapes are made with vegetable glue for reliability and various advantages over animal glue tapes.

Cardboard box sealing adhesive penetration

Adhesive penetrates into the cardboard fibers creating a strong and reliable bond.

Tamper Proof

As a result of the adhesive penetration to the cardboard box, removing the tape leaves a mark which indicates tampering. Such feature guarantees maximum protection against theft and tampering.

Nature Friendly

Gummed paper tapes are made from natural materials and are 100% recyclable.

Temperature variation proof

Temperature extremes do not modify the tapes features. Once a box or a package is seal using a gummed paper tape, it remains sealed even under extreme heat, humidity and cold.

STEP Pneumatic for Bottom Cardboard Stapler

The STEP Pneumatic Stapler is a hand-held tool designed specifically for sealing cardboard boxes. It is very easy to use and is very portable. This specialized stapler is compatible for width 35mm and height 15/18mm. or 35mm and height 18/22mm

STEP AD19 35x(15/18) **Item no.: 42218050**

STEP AD22 35x(18/22) Lager **Item no.: 42218060**

It makes a very reliable seal perfect for most boxed products.

Machine size. 342x115x220mm

Weight : 2,22kgs

PN pressure: 5-7kg/cm²

Take over: 6mm



Staples:

Item no.	Dimension
59553515	35x15mm
59553518	35x18mm
59553522	35x22mm

STEP Manual Bottom Cardboard Stapler

The STEP Manual Stapler is a hand-held made for sealing cardboard boxes.

STEP ST103 35x15 **Item no.: 42218080**

STEP ST105 35x18 **Item no.: 42218090**

It makes a very reliable seal perfect for most boxed products.



STEP Pneumatic Stand Bottom Cardboard Stapler

The STEP Pneumatic Stand Bottom Cardboard Stapler is frame mounted for easy hands free stapling of cardboard boxes. Place the carton, press the foot pedal and your box is almost ready. This specialized stapler is compatible for width 34,7mm and height 15/18/22mm.

Specification:

Dimensions:	830x600x1245mm
Weight:	29,3Kgs
Working Height:	930mm
Throat Depth:	320mm
PN pressure:	5.5-6bar
Staple magazine	200 pcs. 34,7x15/18/22
Country of Origin	Taiwan

STEP PSB3522 **Item no.: 42218100**

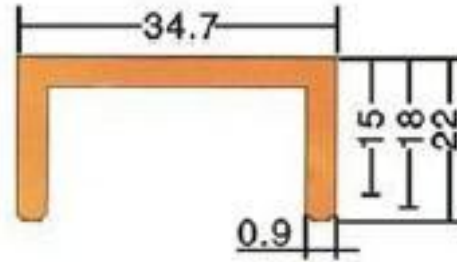

Nails/Staples for Cardboard Staplers

Type	Description	Item no.	Pcs/carton
32x15	Staple 32x15mm	59553215	2.500 inside small box
32x18	Staple 32x18mm	59553218	25.000 master carton
35x15	Staple 34,7x15mm	59553515	2.500 inside small box 20.000 master carton
35x18	Staple 34,7x18mm	59553518	
35x22	Staple 34,7x22mm	59553522	

STEP Corrugated Cardboard Boxes

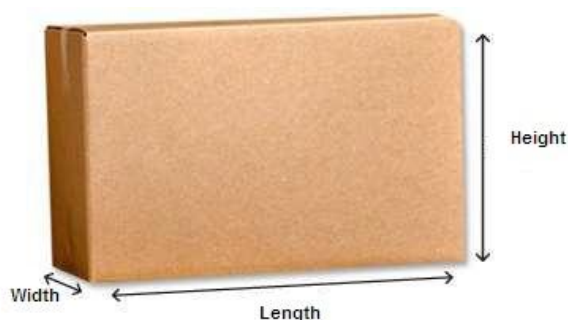

Item Numbers	Dimensions in mm (LxWxH)
62000030	190 x 100 x 70
62000190	600 x 600 x 480
62000010	140 x 140 x 150
62000012	155 x 155 x 120
62000015	170 x 170 x 180
62000020	186 x 186 x 74
62000025	186 x 186 x 165
62000032	191 x 191 x 185
62000034	225 x 210 x 150
62000035	230 x 230 x 230
62000040	250 x 250 x 250
62000036	260 x 220 x 70
62000045	270 x 270 x 140
62000050	275 x 275 x 275
62000054	283 x 186 x 172
62000052	284 x 185 x 165
62000133	291 x 291 x 185
62000055	300 x 200 x 200
62000112	310 x 230 x 100
62000129	310 x 230 x 100
62000065	310 x 230 x 180
62000070	310 x 230 x 250
62000075	310 x 230 x 250
62000080	310 x 310 x 140
62000085	315 x 315 x 300
62000090	340 x 254 x 289
62000092	341 x 102 x 92
62000093	341 x 292 x 92
62000095	350 x 310 x 110
62000220	355 x 355 x 355
62000098	365 x 210 x 213
62000100	370 x 370 x 280
62000105	379 x 284 x 165
62000135	379 x 284 x 347
62000136	380 x 185 x 165
62000109	380 x 260 x 190

Item Numbers	Dimensions in mm (LxWxH)
62000108	380 x 280 x 250 mm
62000112	384 x 252 x 140 mm
62000114	389 x 289 x 181 mm
62000111	389 x 389 x 381 mm
62000113	390 x 350 x 380 mm
62000116	400 x 260 x 180 mm
62000115	400 x 300 x 250 mm
62000118	405 x 310 x 260 mm
62000118	410 x 260 x 220 mm
62000120	410 x 410 x 410 mm
62000125	420 x 420 x 280 mm
62000130	425 x 225 x 200 mm
62000101	432 x 305 x 213 mm
62000140	440 x 320 x 300 mm
62000141	440 x 330 x 100 mm
62000142	450 x 350 x 160 mm
62000145	455 x 305 x 255 mm
62000151	455 x 330 x 420 mm
62000148	460 x 260 x 70 mm
62000147	460 x 336 x 325 mm
62000150	475 x 475 x 475 mm
62000155	510 x 280 x 245 mm
62000102	530 x 440 x 350 mm
62000160	540 x 290 x 160 mm
62000227	565 x 350 x 265 mm
62000138	580 x 375 x 358 mm
62000180	580 x 380 x 165 mm
62000181	589 x 389 x 181 mm
62000182	589 x 389 x 281 mm
62000183	589 x 389 x 381 mm
62000193	590 x 290 x 210 mm
62000192	590 x 390 x 500 mm
62000188	590 x 390 x 980 mm
62000184	591 x 391 x 310 mm
62000185	591 x 391 x 340 mm
62000187	591 x 391 x 364 mm
62000189	591 x 391 x 460 mm
62000195	600 x 410 x 510 mm
62000202	690 x 500 x 500 mm
62000205	700 x 390 x 500 mm
62000216	785 x 395 x 460 mm
62000218	790 x 590 x 375 mm
62000210	820 x 490 x 300 mm



STEP DNC L15 Series top/bottom Carton Tape Closer

DNC Spain offers a wide range of Semi automatic Carton Sealers for cartons in series, that can be adapted to any range of production demand. Special options and variants available on request.

Semi-automatic equipment designed for the upper and base sealing of boxes with adhesive tape or gummed paper. It can be manually adjusted quickly and simply to work with different box formats of reduced dimensions and weights. These machines can be relocated easily and are ideal to carry light loads to a medium level of production.



MODEL	BT15CS	L15CS/E	L15CS	D17NC	D18NC	D19NC	PE17NC
Sealing type	Tape						Gummed Paper
Maximum case sizes (outer sizes)	L	-	-	-	-	-	-
	W	500 mm	500 mm	500 mm	650 mm	800 mm	1000 mm
	H	500 mm	500 mm	500 mm	650 mm	900 mm	1000 mm
Minimum case sizes (outer sizes)	L	120 mm	150mm	120 mm	150 mm	150 mm	150 mm
	W	150 mm	160 mm	110 mm	110 mm	110 mm	110 mm
	H	120 mm	120 mm	120 mm	115 mm	115 mm	115 mm
Belt Speed	23 m/min	20 m/min	23 m/min	22 m/min			
TECHNICAL DATA							
Weight	153 kg	131 kg	160 kg	175 kg	190 kg	230 kg	290 kg
Dimensions	L	1637 mm	1620 mm	1713 mm	1000 mm	1000 mm	1825 mm
	W	754 mm	804 mm	854 mm	1015 mm	1164 mm	1364 mm
	H	1400 mm	1237 mm	1350 mm	1320 mm	1711 mm	1808 mm
Drive belts	Top & bottom			Lateral			
	Belt height	50 mm	50 mm	50 mm	50 mm	50 mm	50 mm
Tape width	50 mm	50 mm	50 mm	50 mm	75 mm	75 mm	75 mm
Working height	600/800 mm			520/750 mm		700/900 mm	
UTILITIES							
Electrical power	230V II+T			230/400V III+T		230/400V III+N+T	
Electrical consumption	0,45 kW/h			0,40 kW/h		1 kW/h	
Pneumatic pressure				NO		6 bar	
Air consumption				NO		0,20 l/caja	
OPTIONS							
75 mm taping heads	-	✓	✓	✓	✓	✓	✓
38 mm taping heads	-	-	-	✓	-	-	-
Only bottom sealing version	-	✓	✓	✓	✓	✓	✓
3 flap closing guide 3 solapas	-	✓	✓	✓	✓	✓	✓
Stainless steel	-	-	✓	✓	✓	✓	✓

STEP Item no.:

BT15CS item no.:
42000151

L15CS item no.:
42000150

D17NC item no.:
42000170

D18NC item no.:
42000180

D19NC item no.:
42000190

PE17NC item no.:
42000171

STEP DNC L25 Random top/bottom Tape Carton Sealer

Semi-automatic equipment designed for the upper and base sealing of boxes with adhesive tape or Gummed paper. It uses automatic settings to work with alternating forms of box sizes and weights. These Machines can be relocated easily and are ideal to carry light loads to a medium level of production.

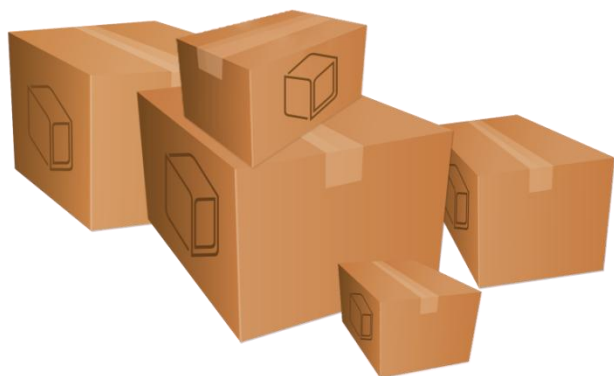

MODEL	L25CS	D27NC	D28NC	PE27NC
Sealing type	Tape	Tape	Tape	Gummed paper
Maximum case sizes (outer sizes)	L - W 600 mm H 600 mm	- 650 mm 650 mm	- 800 mm 850 mm	- 650 mm 650 mm
Minimum case sizes (outer sizes)	L 120 mm W 110 mm H 120 mm	150 mm 110 mm 115 mm	150 mm 110 mm 115 mm	250 mm 120 mm 150 mm
Belt Speed	23 m/min		22 m/min	
TECHNICAL DATA				
Weight	130 kg	150 kg	170 kg	280 kg
Dimensions	L 1160 mm W 1030 mm H 1550 mm	1000 mm 1015 mm 1600 mm	1000 mm 1164 mm 1600 mm	1825 mm 850 mm 2200 mm
Drive belts	Lateral			
Belt height	50 mm			
Tape width	50 mm	50 mm	50 mm	75 mm
Working height	680-880 mm	520-750 mm	520-750 mm	700-900 mm
UTILITIES				
Electrical power	230V II+T		230/400V III+T	
Electrical consumption	0,45 kW/h	0,40 kW/h	0,40 kW/h	1 kW/h
Pneumatic pressure	6 bar			
Air consumption	25 l/case	0.40 l/case	0.60 l/case	0.80 l/case
OPTIONS				
75 mm taping heads	✓	✓	✓	-
38 mm taping heads	-	-	-	-
Only bottom sealing version	✓	✓	✓	✓
3 flap closing guide	-	-	-	-
Stainless steel	-	✓	✓	✓

STEP Item no.:

L25CS item no.:
42000250

D27NC item no.:
42000270

D28NC item no.:
42000280

PE27NC item no.:
42000271

STEP DNC L35 Series top/bottom Auto Flap Folder Tape Carton Sealer

DNC Spain offers a wide range of Automatic flap fold Carton Sealers for cartons in series, that can be adapted to any range of production demand.

Special options and variants available on request

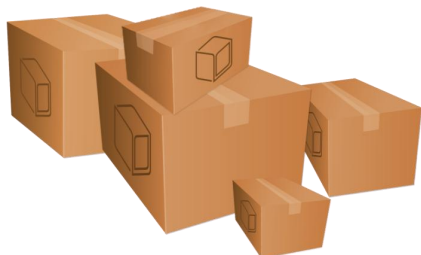

Automatic equipment designed for the upper and base sealing of boxes with adhesive tape or gummed paper. It can be manually adjusted quickly and simply to work with different box formats of reduced dimensions and weights. These machines incorporate the closing of the upper flaps and are designed to be integrated into production lines. They are robust, reliable and ideal for all different weights whilst being able to endure high levels of production.

MODEL	L35CS	D37NC	D38NC	D39NC	PE37NC	
Sealing type	Tape, Hotmelt glue				Gummed paper	
Maximum case sizes (outer sizes)	L	610 mm	750 mm	750 mm	750 mm	
	W	500 mm	650 mm	800 mm	950 mm	
	H	500 mm	650 mm	900 mm	1000 mm	
Minimum case sizes (outer sizes)	L	120 mm	150 mm	150 mm	150 mm	
	W	110 mm	110 mm	110 mm	110 mm	
	H	120 mm	115 mm	115 mm	115 mm	
Belt Speed	23 m/min		22 m/min			
TECHNICAL DATA						
Weight	300 kg	310 kg	330 kg	360 kg	390 kg	
Dimensions	L	1960 mm	1828 mm	2480 mm	2480 mm	2480 mm
	W	900 mm	1014 mm	1315 mm	1315 mm	850 mm
	H	1990 mm	1514 mm	1625 mm	1850 mm	2200 mm
Drive belts	Lateral					
Belt height	50 mm	75 mm	75 mm	75 mm	75 mm	
Tape width	50 mm	50 mm	75 mm	75 mm	75 mm	
Working height	680-880 mm		520-750 mm		700-900 mm	
UTILITIES						
Electrical power	230V II+T		230/400V III+T		230/400V III+N+T	
Electrical consumption	0,45 kW/h		0,40 kW/h		1 kW/h	
Pneumatic pressure	6 bar					
Air consumption	0,33 l/case		0,35 l/case		0,50 l/case	
OPTIONS						
75 mm taping heads	✓	✓	✓	✓	✓	
38 mm taping heads	-	✓	-	-	-	
Only bottom sealing version	-	-	-	-	-	
3 flap closing guide	-	-	-	-	-	
Stainless steel	-	✓	✓	✓	✓	

STEP Item no.:

L35CS item no.:
42000350

D37NC item no.:
42000370

D38NC item no.:
42000380

D39NC item no.:
42000390

PE37NC item no.:
42000371

STEP DNC D45NC Fully Automatic Random Carton – Built in Spain by DNC

The fully automatic, self-adjusting, top flap folding carton sealer, model STEP D45NC, meets all the possible performances and versatility such a machine, using selfadhesive tape, should deliver.

Features

- 50 mm (2") taping heads
- Automatic upper flaps pneumatic folder.
- Pneumatical width and height setting.
- Two motors for synchronized side belt drive.
- Upper flaps folding rails.
- Height adjustable legs.
- Adjustable air pressure gauge
- Upper structure supported by 4 masts.
- Inbuilt air filtering and lubricating system.
- Adjustable flap folding timing both at activation and deactivation.
- Case dosing and indexing by conveyor belt
- STEP Item no.: 42000450

Option

- 75 mm (3") taping heads.
- Different types of roller bed extensions.
- Braked casters.
- Wider or raised belts for unstable or heavy cartons.
- Other special adaptations upon request



Carton size					
Width		Length		Height	
min	max	min	max	min	max
400	optional	optional	optional	optional	optional

STEP XT 9036 SERIES SEMI AUTO SEALER – Low Price Asia built Machine**Features**

Side belts driven suit for sealing narrow carton.
Compact and durable design, easy to operate.

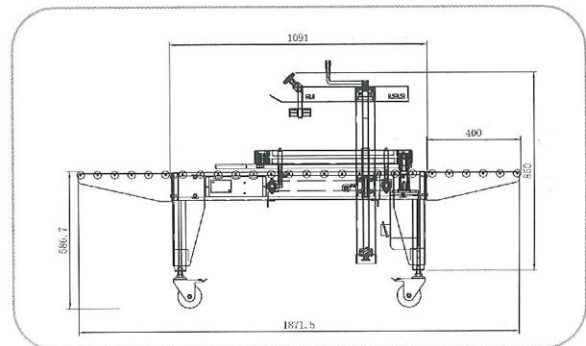
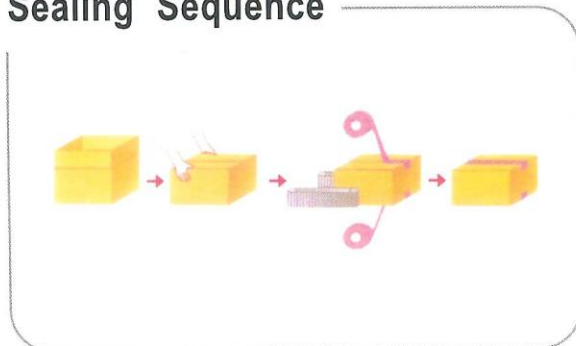
Sealing Sequence**Standard Specification**

Carton size	(L)150-∞ (W)100-500(H)100-500mm
Table height	(min.) 580 (max.) 780mm
Working speed	700-1200(ctns/hr)
Machine size	(L)850 (W)830 (H)1200-1600mm
Power	110/220V single phase, 50/60Hz or, specified by client
Tape width	48mm,75mm (alternative use)
Machine net weight	Approx.95kgs