

Sal-Tech Easy Packaging

Fully Automatic Strapping Machines



STEP TP-601 Fully Automatic Series

More Features



Auto Strap Feeding

Simply insert the strap into the feeding rollers from the coil side of the machine and then push the "reset" button. The machine will automatically feed itself without the need to access to the inside of the machine. No need to remove it from the line for strap feeding. Designed for easy strap loading.



Auto Strap Ejector

Loop-eject clears unwanted strap automatically if the machine is accidentally activated without a package. Effectively eliminates downtime due to strap jamming and other similar issues.



Hinged Top Plates

The top plates opens wide for quick cleaning, inspection, and maintenance of strapping head, strap-feed and tensioning unit.



Belt Transmission

Instead of using roller chain, belt transmission system ensures long operational life and quiet operation.



Electronic Tension Control

Strap tension can be adjusted accurately by the simple turn of a dial. Easy operation.

Specifications	
Strap Width	8 mm-12 mm
Strap Tension	7 kg-70 kg
Conveyor Speed	30 meter/Minute
Table Height	825 mm
Net Weight	330 kg
Electrical Requirements	Three Phase According to Local Standard

STEP TP-601 Series Fully Automatic Strapping Machines



STEP TP-601A-CE	STEP TP-601B-CE
41180342	41181342
Table Rollers	Belts on Table

Enhanced Fully Automatic Strapping Machine with arch width 850mm and height 600mm, table height 820 mm, for 12mm PP Strap and ø200 core.

Features:

- Electronic Tension Control
- Re shoot of strap
- Automatic loading of strap
- Electrical reset bottom
- Zero loop cast out
- Transport speed 30m/min.
- Single strap, two or more or transit
- Capacity up to 18 parcels /minute

Options

- Siemens PLC control
- Variable conveyor speed: 18 to 42 meter/min
- Stainless steel frame SUS 304 (STEP TP-601AS)
- Safety Guards

Arch Sizes

H	W	850	1050	1250
400		•	•	•
600		Available	•	•
800		•	•	•
1000		•	•	•

- On Order basis

Line for Cross Strapping of large boxes, using 2 units of STEP TP-601B



For more information call us:

Telephone: +45-7027 2220

Skype: easy.packaging

STEP TP601BP-CE

Fully Automatic Transit with Press

The STEP TP-601BP is a Fully Automatic Strapping Machine with transit capability and features a Pneumatic Press. The machine has a belt-driven table with speeds up to 30 meters per minute. It is ideal for strapping printed products such as newspapers and magazines. It is also applicable for strapping corrugated boxes and other similar packaging. A Stainless Steel model also available.

Features

- Multiple strap function for single, double, continuous strapping or transit mode
- Up and down stream interlock with complete plug connector
- Easy bundle flow direction change
- Automatic end-strap detection and ejection
- Electronic Tension Control

Options

- Siemens PLC control
- Variable conveyor speed: 18 to 42 meter/minute
- Stainless Steel frame SUS 304 (STEP TP-601BPS)
- Safety Guards

Arch Sizes

H	W	850	1050	1250
400		•	•	•
600	Available		•	•
800		•	•	•
1000		•	•	•

- On Order basis

Main Features



Auto Strap Feeding

Simply insert the strap into the feeding rollers from the coil side of the machine and then push the "reset" button. The machine will automatically feed itself without the need to access to the inside of the machine. No need to remove it from the line for strap feeding. Designed for easy strap loading.



With Pneumatic Press

STEP TP-601BP is ideal to strap compressible material such as corrugated papers, paper sheets, plastic sheets, bags...etc



Hinged Top Plates

Opens wide for quick cleaning, inspection, and maintenance of strapping head, strap-feed and tensioning unit.



Auto Strap Ejector

Loop-eject clears unwanted strap automatically if the machine is accidentally activated without a package. Effectively eliminates downtime due to strap jamming and other similar issues.



Belt Transmission

Instead of using roller chain, belt transmission system ensures long operational life and quiet operation.



Specifications	
Strap Width	8 mm-12 mm
Strap Tension	7 kg-70 kg
Conveyor Speed	30 meter/Minute
Table Height	825 mm
Net Weight	330 kg
Electrical Requirements	Three Phase According to Local Standard

Product Overview:

STEP TP-702B

The STEP 702B is a fully automatic strapping machine is capable of strapping up to 65 straps per minute, with width ranges from 5mm, 6mm & 9mm strap. This machine is dedicated to use only PP strap due to its temperature requirement, and for a more reliable means of packaging. With its Dispenser Release Switch, this machine makes it easier to pull the strap from the strap dispenser for waist-high auto strap feeding.

Features:

- Durable Strapping Head
- Compact Design
- Suitable for Small Package Strapping
- Automatic Strap Feeding
- Automatic Strap Ejection
- Modifiable Conveyor Speed
- Modifiable Table Height
- Several Strap Mode (single, double, continuous, or transit)
- Hinged Top Plates
- E-Tension Control
- Variable Bundle Flow Direction Change
- Up and Down Stream Interlock



Electronic Tension Control

The operating control panel with LCD display is located on upper side of the machine for easy access. Strap tension can be adjusted accurately by a simple turn of the dial.

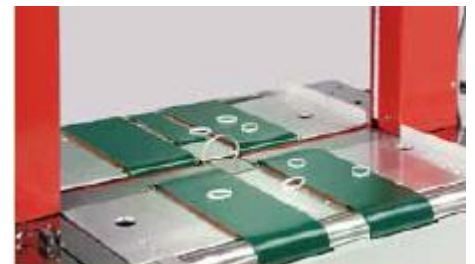

Auto Strap Ejector

Loop-eject clears unwanted strap automatically if the machine is accidentally activated without a package.



Waist-High Auto Strap Feeding

Friendly design to feed the strap automatically from the upper side of the coil without the need to access to the bottom of the machine.

Specifications	
Strap Width	5mm, 6mm, 9mm or 12mm
Tension Range	1-32 Kg (for 5mm, 6mm, and 9mm) 1-55 Kg (for 12mm)
Speed	Up to 40 packages per min. (Cycle speed up to 65 straps per min.)
Net Weight	225 Kg
Electrical Requirements	110V, 220V, 230V, 240V 50/60Hz 1 PH 220V, 380V, 400V, 415V 50/60Hz 3PH
STEP Item no.	41197010 for 230V version 41197010-110 for 110V version

STEP TP-702BP

The other version of this STEP-TP 702B comes with a dual Pneumatic press for a more secured packaging solution for your goods is the STEP-TP 702BP. This machine incorporates the latest technology that provides ultimate reliability in packaging solution. Just like the previous version, this machine comes with standard front foot bar switch makes machine operation in a very easy way. Ergonomic cycle initiation design and user friendly.

Features:

- Reliable Strapping Head
- Compact Design
- Installed Pneumatic Press
- Free Access to Strap Guides (Registered Patent)
- Hinged Top Plates
- Variable Bundle Flow Direction Change
- Up and Down Stream Interlock
- Modifiable Conveyor Speed
- Modifiable Table Height
- Automatic Strap Feeding
- Automatic Strap Ejection
- E-Tension Control
- Several Strap Mode (single, double, continuous, or transit)



With Pneumatic Press

This machine is ideal to strap compressible material such as corrugated papers, paper sheets, plastics sheets, bags etc.

Free Access to Strap Guides (patents registered)

Unlocking the guides enables free and quick access to the strap guides without use of any tools. The Most maintenance friendly design.



Specifications	
Strap Width	5mm, 6mm, 9mm or 12mm
Tension Range	1-32 Kg (for 5mm, 6mm, and 9mm) 1-55 Kg (for 12mm)
Speed	Up to 36 packages per min. (Cycle speed up to 65 straps per min.)
Net Weight	250 Kg
Pneumatic Bar	6 bar
Electrical Requirements	110V, 220V, 230V, 240V 50/60Hz 1 PH 220V, 380V, 400V, 415V 50/60Hz 3PH
STEP Iitem no.	41197020 for 230V version 41197020-110 for 110V version

Fully Automatic Strapping Machines – STEP TP-702N Series

STEP TP-702N is an upgraded fully automatic strapping machine, designed specifically for the printed media industry. It is particularly suitable for newspaper, magazine, commercial and mail order strapping.

STEP TP-702NS

High Speed Strapping Machine for Single and Parallel Strapping



The STEP TP-702NS is a Fully Automatic Strapping Machine. With its High Speed Strapping, it can be integrated into most production lines and be utilized with various applications.

Main Features

- Robust & Compact Mechanical Strapping Head
- Patented Automatic Tension Control for various bundle dimensions
- Dual Pneumatic Press
- Up and Down Stream Interlock with complete plug connection
- Fully Automatic Operation with Variable Conveyor Speed
- Siemens PLC Control and Touch Panel
- Light Tree Alarm (Dual Lamp)
- Free Access to Strap Guides (Patents Registered)
- Easy Access to Strapping Head (Patents Registered)
- Quick Coil Change
- Automatic End-Strap Detection and Ejection
- Adjustable Table Height between 800 mm and 900 mm
- Automatic Strap Loop Ejection

STEP Item no.: 41204110

Options

- Energy Saving Transit with Auto Sleep Mode
- Operator Friendly Low Strap Sensor (Triple Lamp)
- Soft Press for Convex Bundle
- Lower Adjustable Table Height (730 mm - 800 mm)
- Automatic Side Squaring
- Reverse Bundle Flow
- Low Volume Bundle Bypass
- Movable Caster

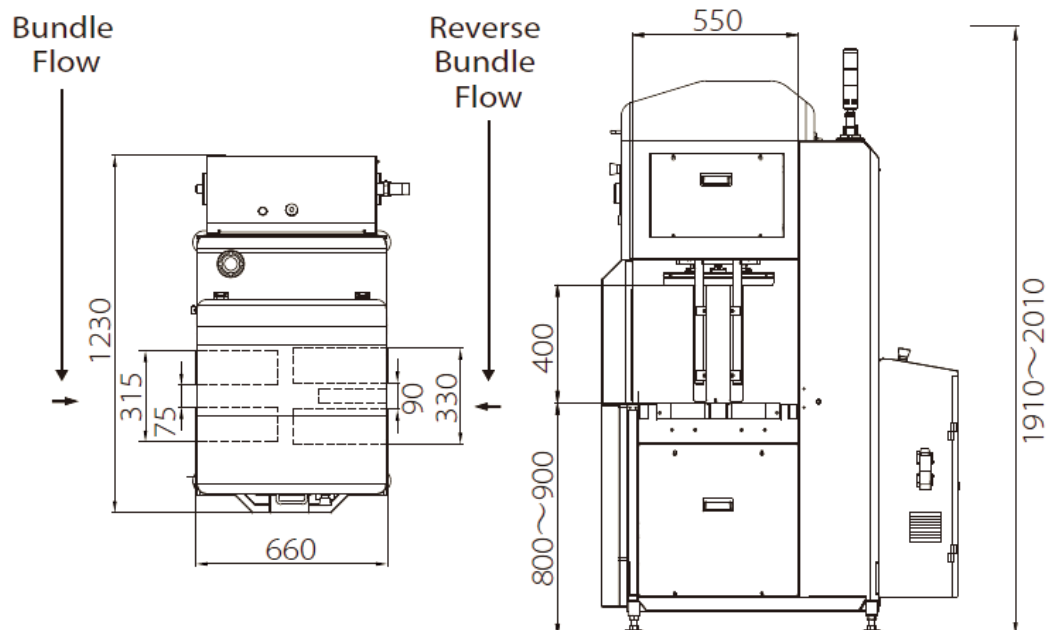

STEP TP-702NL

Fully Automatic Longitudinal Strapping Machine for Bundle Strapping in Transport Direction

The STEP TP-702NL is a Fully Automatic Longitudinal Strapping Machine. The bundle is strapped in the transport direction.

Main Features

- Robust & Compact Mechanical Strapping Head
- Patented Automatic Self-Adjusting Strap Chute (Patents Registered)
- Patented Automatic Tension Control for various bundle dimensions
- Up and Down Stream Interlock with Complete Plug Connection
- Fully Automatic Operation with Variable Conveyor Speed
- Siemens PLC Control and Touch Panel
- Light Tree Alarm (Dual Lamp)
- Free Access to Strap Guides (Patents Registered)
- Easy Access to Strapping Head (Patents Registered)
- Quick Coil Change
- Automatic End-Strap Detection and Ejection
- Adjustable Table Height between 800 mm and 900 mm
- Automatic Strap Loop Ejection

STEP Item no.: 41204120

Options

- Energy Saving Transit with Auto Sleep Mode
- Operator Friendly Low Strap Sensor (Triple Lamp)
- Lower Adjustable Table Height (730 mm - 800 mm)
- Automatic Side Squaring
- Reverse Bundle Flow
- Low Volume Bundle Bypass
- Movable Caster



Bundle
Flow

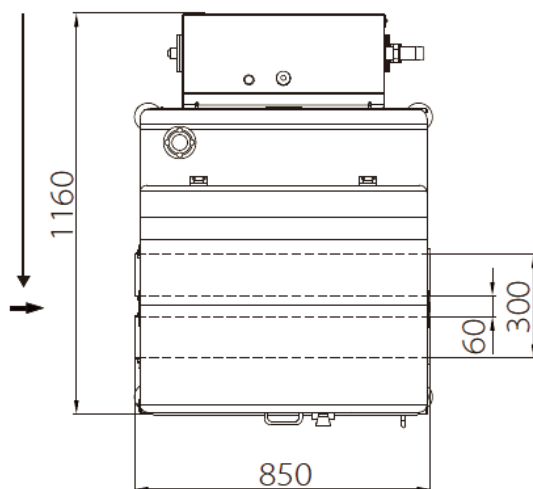

Reverse
Bundle
Flow

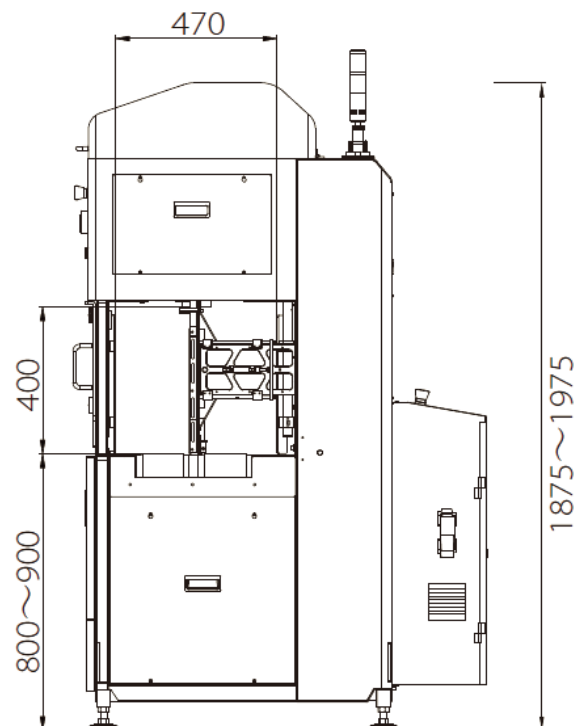

STEP TP-702NIL

In-Line Cross Strapping System without Bundle Turning

The STEP TP-702NIL is a Fully Automatic Strapping System for In-Line Cross Strapping. The design without bundle turning can secure the integrity of the bundle for cross strapping.

Main Features

- Light Tree Alarm (Dual Lamp)
- Waist-High Auto Strap Feeding
- Up and Down Stream Interlock with Complete Plug Connection
- Fully Automatic Operation with Variable Conveyor Speed
- Patented Automatic Tension Control for Various Bundle Dimensions
- Siemens PLC Control and Touch Panel
- Dual Pneumatic Press
- Adjustable Compression System
- Automatic End-Strap Detection and Ejection
- Automatic Strap Loop Ejection
- Adjustable Table Height between 800 mm and 900 mm
- Quick Coil Change

STEP Item no.: 41204130

(STEP TP-702NIL consists of STEP TP-702NL Longitudinal Strapping Machine and STEP TP-702NS Strapping Machine)

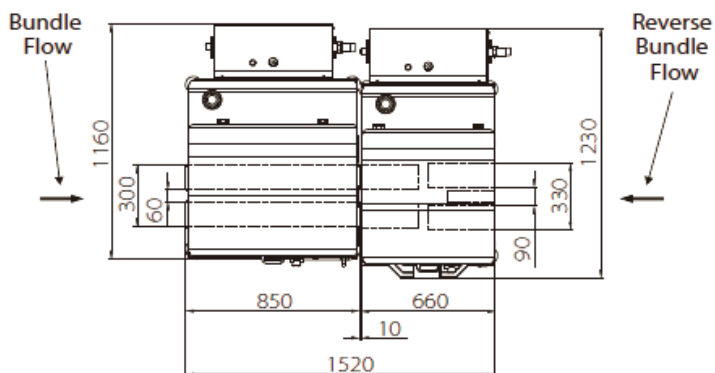

Options:

- Energy Saving Transit with Auto Sleep Mode
- Operator Friendly Low Strap Sensor (Triple Lamp)
- Lower Adjustable Table Height (730 mm - 800 mm)
- Automatic Side Squaring
- Reverse Bundle Flow
- Low Volume Bundle Bypass
- Movable Caster

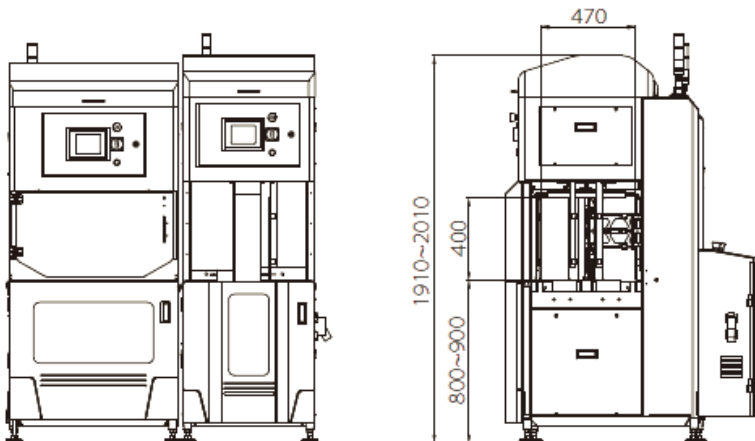

STEP TP-702NAD

Cross Strapping System with Multi-Angle Diverter for Transport Direction Change

The STEP TP-702NAD is a Fully Automatic Strapping System with Multi-Angle Diverter for Cross Strapping requirements. STEP TP-702NAD consists of two (2) STEP TP-702NS Strapping Machine and one (1) N1-AD Angle Diverter.

Main Features

- Robust & Compact Mechanical Strapping Head
- Patented Automatic Tension Control for Various Bundle Dimensions
- Dual Pneumatic Press
- Up and Down Stream Interlock with Complete Plug Connection
- Waist-High Auto Strap Feeding
- Fully Automatic Operation with Variable Conveyor Speed
- Siemens PLC Control and Touch Panel
- Light Tree Alarm (Dual Lamp)
- Free Access to Strap Guides (Patents Registered)
- Easy Access to Strapping Head (Patents Registered)
- Quick Coil Change
- Automatic End-Strap Detection and Ejection
- Automatic Strap Loop Ejection
- Multiple Infeed and Delivery Directions
- Adjustable Table Height between 820 mm and 900 mm



STEP Item no.: 41204140

Options:

- Energy Saving Transit with Auto Sleep Mode
- Operator Friendly Low Strap Sensor (Triple Lamp)
- Soft Press for Convex Bundle
- Automatic Side Squaring
- Low Volume Bundle Bypass
- Movable Caster



N1-AD Angle Diverter

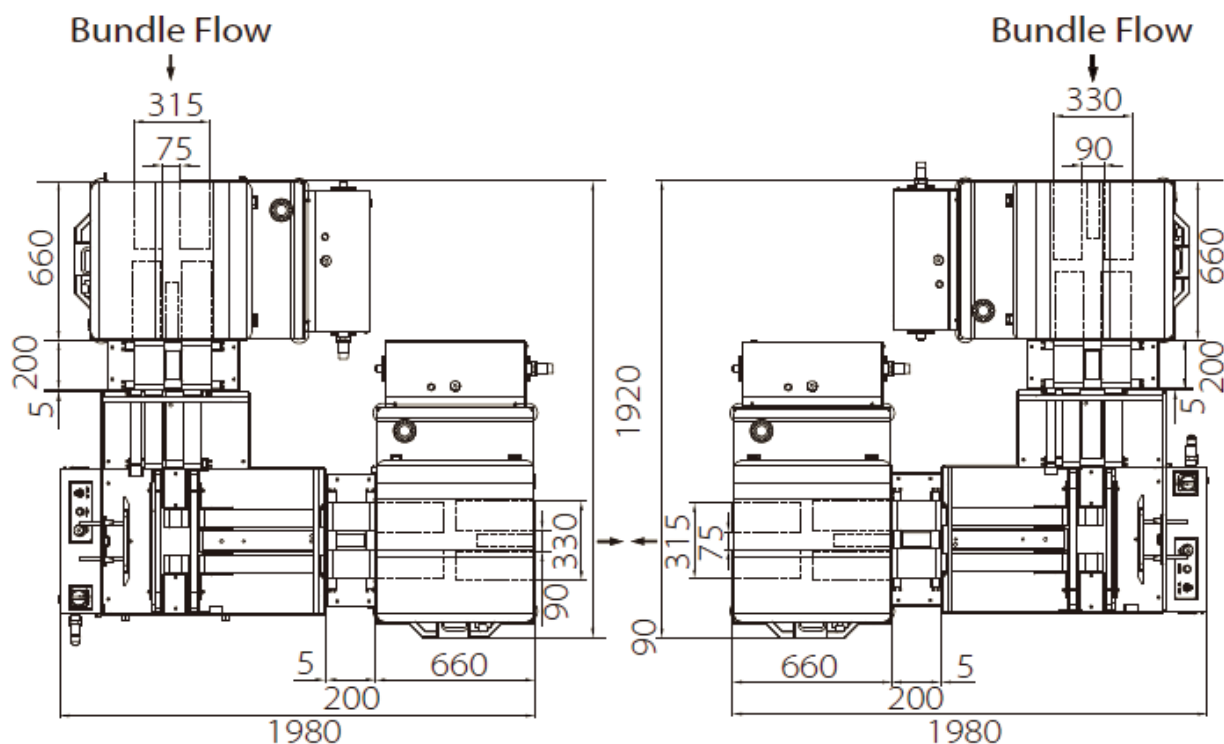

More Features for the STEP TP-702N Series



Robust & Compact Mechanical Strapping Head

The STEP TP-702N Series uses the latest DC Brushless Motor Technology to provide the highest level of accuracy and reliability on the market. All motors are German-made. The strapping head has no belts, clutches or pulleys. It is designed with up-to-date technology with few moving parts. With 30% fewer parts, STEP TP-702N requires fewer adjustments, has fewer wear components, and requires less maintenance. The simple design of the STEP TP-702N minimizes the maintenance cost.



Automatic Self-adjusting Strap Chute (Patents Registered)

The strap chute can detect the incoming bundle height and stop at the accurate position. This intelligent design can streamline your strapping line and increase the speed of the strapping cycle.



Siemens Touch Panel

Provides easy adjustments, operating instructions and troubleshooting guides. Easy TEACH-IN programming without the need to adjust the setting when changing to different bundle size.



Easy Access to Strapping Head (Patents Registered)

The whole strapping head can be completely pulled out during production. With this most user friendly design, operators can perform maintenance directly without pulling out the machine from the production line.



Free Access to Strap Guides (Patents Registered)

Unblock the guides enabling free and quick access to strap guides without the use of any tools. The most maintenance friendly design.

Model		STEP TP-702NS	STEP TP-702NL	STEP TP-702NIL	STEP TP-702NAD
Capacity (bundle/min)		42(single) 24(double)	up to 31 bundle/minute		25 bundle/min (single or double)
Bundle Sizes (mm)	Length	-	500 (max) 210 (min)		-
	Width	500 (max) 120 (min)	450 (max) 120 (min)		500(max) 210(min)
	Height	400 (max) 10 (min)	400 (max) 10 (min)		400(max) 10(min)
Bundle Weight		25 kg (max)			
Strap Width		5mm/6mm/9 mm P.P. Strap			
Strap Tension		1-32 kg			
Strap Coil		200mm (150mm Optional)			
Electrical Requirements		3 Phase According to Local Standard			
Net Weight		420 kg	460 kg	880 kg	1045 kg

STEP TP-601YPT

Automatic Side Seal Strapping Machine for PET and PP Strapping applications

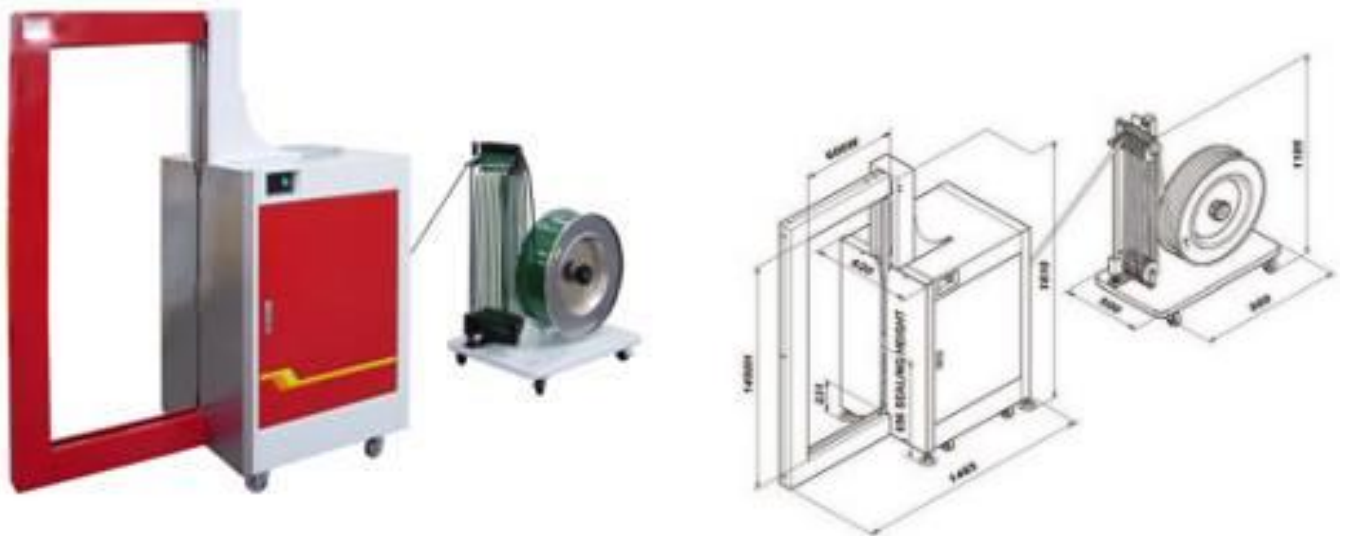

The STEP TP-601YPT strapping machine is ideal for building into automatic lines and applications where the strap goes around the large product or pallet. It uses either PET or PP strap and friction welding. The machine has all modern features according to industrial demands such as electronic tension control, re-shoot, auto strap feed, auto strap ejector, operated by Siemens PLC.

Options:

- Project applications
- Roller conveyor built in.

Specifications	
Strap Width	12mm opt. 9 mm or 15.5 mm
Strap types	PET or PP
Core diameter	Ø406mm (option ø280/200)
Strap Tension	20kg-150kg
Standard arch size	D600mm x H1450mm
Speed	11 straps per minut
Minimum package size	W200mm x H200mm
Net Weight	355 kg
Electrical Requirements	3x380V 50Hz
Item no.:	41187243-A60.145



STEP TP-601YPT-T version with conveyor

Item no.: 41120310

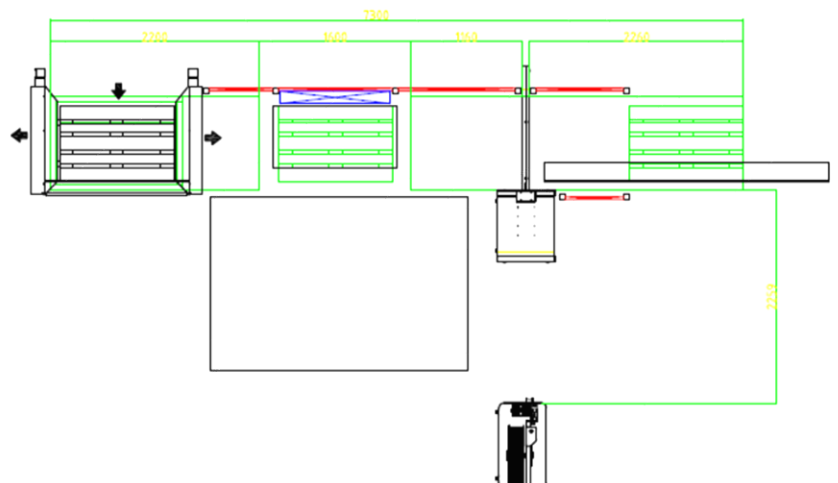

STEP TP-702Y and STEP TP-702YA Side-Seal Strapping Machine

STEP TP-702Y and STEP TP-702YA are high speed side-seal strapping machines. With all the standard features this series processes, STEP TP-702Y and STEP TP-702YA offer high reliability and performance. They can be integrated into most production lines and be utilized with various applications.



STEP TP-702Y automatic side-seal machine
Item no.: 41199680



STEP TP-702YA Fully automatic side-seal machine
Item no.: 41199690

Main features

High Strapping Speed

Cycle speed is up to 60 straps per minute.

Robust & Compact Mechanical Strapping Head

Use the latest DC brushless motor technology to provide the highest level of accuracy and reliability on the market.

Free Access to Strap Guides

(patents registered)

Unblock the guides enabling free and quick access to the strap guides without the use of any tools. The most maintenance-friendly design.



Strap Dispenser with Ergonomic Design

The position of strap dispenser is inside the machine frame. It's convenient and energy-saving to change the coil of strap.



Options:

- Without adjustable roller Table (STEP TP-702Y-XT)
- End of cycle and strapping error signals
- (STEP TP-702Y / STEP TP-702Y-XT)
- Siemens PLC control (STEP TP-702YA)
- Operator friendly low strap sensor (triple lamp) (STEP TP-702YA)
- Energy saving transit with auto sleep mode (STEP TP-702YA)
- Press bar (STEP TP-702YA)
- Side pusher (STEP TP-702YA)

Specification:

Strap width: 5, 6, 9 or 12mm

Strap Tension:

- 320N for 5mm or 6mm strap
- 500N for 9mm strap
- 550N for 12mm strap

Speed:

- 60 straps/minute for STEP TP-702Y
- 35 packages /minute for STEP TP-702YA

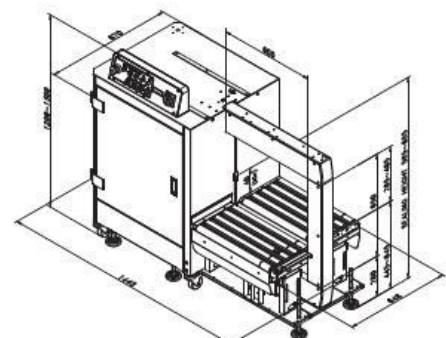
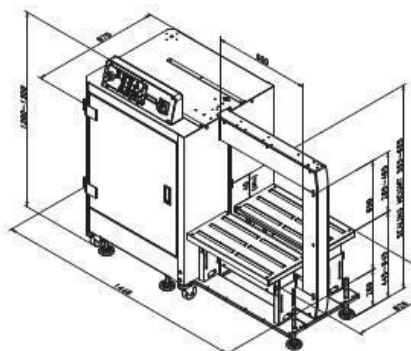

STEP TP-702YM and STEP TP-702YAM

Side-Seal Strapping Machine Wash down Stainless steel

STEP TP-702YM and STEP TP-702YAM are high speed side-seal strapping machines. With all the standard features this series processes, STEP TP-702YM and STEP TP-702YAM offer high reliability and performance. They can be integrated into most production lines and be utilized with various applications.



STEP TP-702YM automatic side-seal machine
Item no.: 41199700

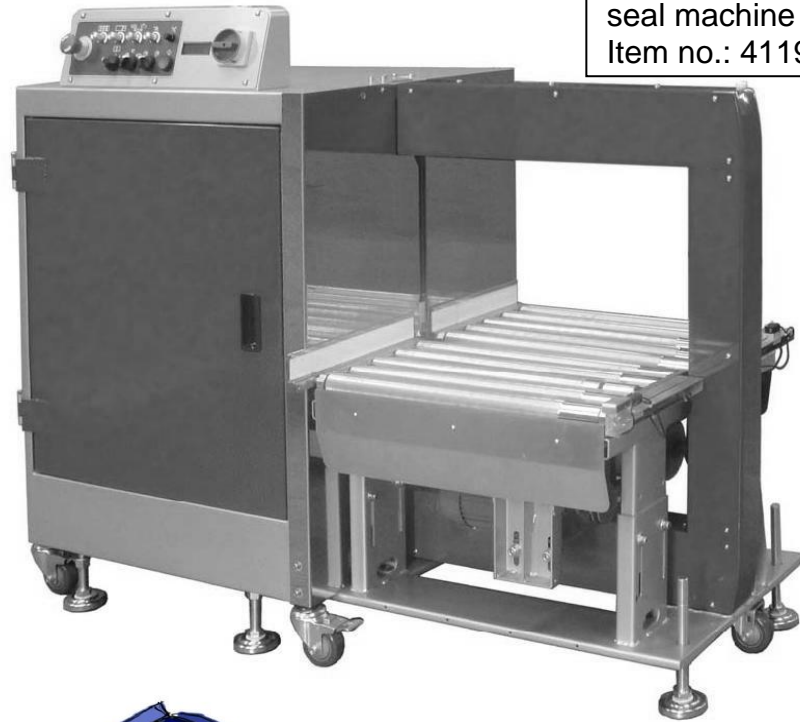

STEP TP-702YAM
Fully automatic side-seal machine
Item no.: 41199710

Main features

High Strapping Speed

Cycle speed is up to 60 straps per minute.

Wash Down for wet environment

Suited for fishing and similar high demand industry.

Robust & Compact Mechanical Strapping Head

Use the latest DC brushless motor technology to provide the highest level of accuracy and reliability on the market.

Free Access to Strap Guides

(patents registered)

Unblock the guides enabling free and quick access to the strap guides without the use of any tools. The most maintenance-friendly design.

Strap Dispenser with Ergonomic Design

The position of strap dispenser is inside the machine frame. It's convenient and energy-saving to change the coil of strap.



Options:

- Without adjustable roller Table (STEP TP-702YM-XT)
- End of cycle and strapping error signals
- (STEP TP-702YM / STEP TP-702YM-XT)
- Siemens PLC control (STEP TP-702YAM)
- Operator friendly low strap sensor (triple lamp) (STEP TP-702YAM)
- Energy saving transit with auto sleep mode (STEP TP-702YAM)
- Press bar (STEP TP-702YAM)
- Side pusher (STEP TP-702YAM)

Specification:

Strap width: 5, 6, 9 or 12mm

Strap Tension:

- 320N for 5mm or 6mm strap
- 500N for 9mm strap
- 550N for 12mm strap

Speed:

- 60 straps/minute for STEP TP-702YM
- 35 packages /minute for STEP TP-702YAM

